

High Purity BioPharm Fittings

Weld x Weld x Clamp Tees – T7WWM

Tube O.D.	A (in)	B (in)	Nominal Wall (in)	PL Finish – SF1	PM Finish – SF4
1/2"	1.88	2.25	0.065	T7WWM-050PL	T7WWM-050PM
3/4"	2.00	2.38		T7WWM-075PL	T7WWM-075PM
1"	2.13	2.63		T7WWM-100PL	T7WWM-100PM
1-1/2"	2.38	2.88		T7WWM-150PL	T7WWM-150PM
2"	2.88	3.38		T7WWM-200PL	T7WWM-200PM
2-1/2"	3.13	3.63		T7WWM-250PL	T7WWM-250PM
3"	3.38	3.88		T7WWM-300PL	T7WWM-300PM
4"	4.13	4.75	0.083	T7WWM-400PL	T7WWM-400PM
6"	5.63	7.13	0.109	T7WWM-600PL	T7WWM-600PM

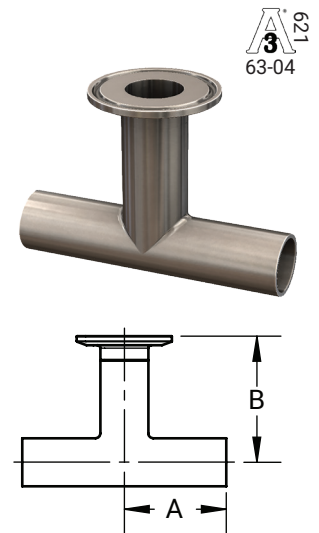

Clamp x Clamp x Clamp Tees – T7MP

Tube O.D.	A (in)	PL Finish – SF1	PM Finish – SF4
1/2"	2.375	T7MP-050PL	T7MP-050PM
3/4"	2.500	T7MP-075PL	T7MP-075PM
1"	2.625	T7MP-100PL	T7MP-100PM
1-1/2"	2.875	T7MP-150PL	T7MP-150PM
2"	3.375	T7MP-200PL	T7MP-200PM
2-1/2"	3.625	T7MP-250PL	T7MP-250PM
3"	3.875	T7MP-300PL	T7MP-300PM
4"	4.750	T7MP-400PL	T7MP-400PM
6"	7.125	T7MP-600PL	T7MP-600PM

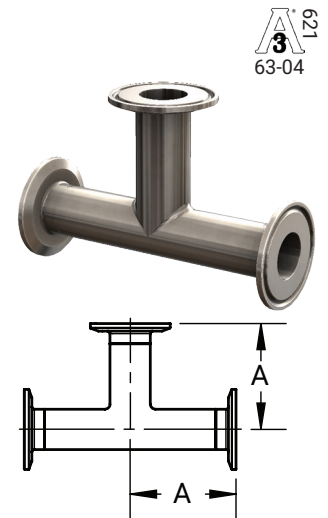

BPE Table DT-4.1.2-4
ASME BPE 2019

NOTE: BPE 2019 Specifications:

PL Finish – SF1

O.D. = 32Ra Mechanically Polished

I.D. = 20Ra Mechanically Polished

PM Finish – SF4

O.D. = 32Ra Mechanically Polished

I.D. = 15Ra Mechanically Polished and Electropolished