

Wilkerson® FRLs

B08-Series Miniature Filters/Regulators

Features

- 0-125 PSI adjusting range
- 5 micron element
- .4 oz. bowl
- Self-relieving
- Supplied with a 0-160 PSI flush mount style gauge

Specifications

- Maximum operating conditions:
 - transparent bowl: 150 PSIG (10.3 bar) and 14°F to 125°F (-10°C to 52°C)
 - metal bowl: 250 PSIG (17.2 bar) and 14°F to 150°F (-10°C to 65.5°C)

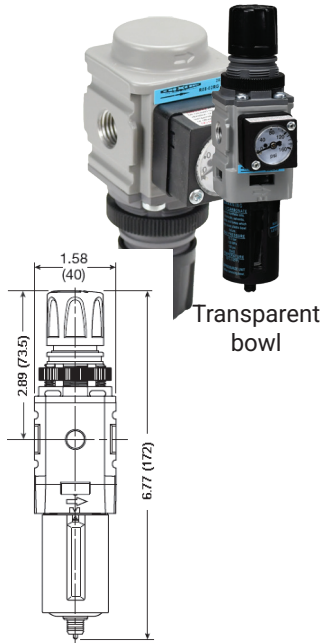

Size	Flow (SCFM)	Transparent Bowl and Guard		Metal Bowl	
		Automatic Drain Part #	Manual Drain Part #	Automatic Drain Part #	Manual Drain Part #
1/4"	73	B08-02AG	B08-02MG	B08-02AGMB	B08-02MGMB

NOTE: See pages 322-326 for accessories.
SCFM ratings at 100 PSIG inlet pressure.

L03-Series Miniature Lubricators

Features

- Polycarbonate/metal bowls
- Adjustable oil feed
- Full view sight dome
- Do not fill under pressure, air supply must be turned off and pressure bled from unit prior to adding oil



Specifications

- Maximum operating conditions:
 - transparent bowl: 150 PSIG (10.3 bar) and 32°F to 125°F (0°C to 52°C)
 - metal bowl: 250 PSIG (17.2 bar) and 32°F to 175°F (0°C to 80°C)

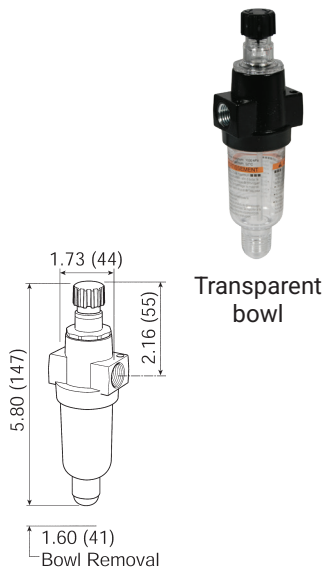

Size	Flow (SCFM)	Transparent Bowl Part #	Metal Bowl Part #
1/8"	20	L03-01A	L03-01AMB
1/4"	20	L03-02A	L03-02AMB

NOTE: SCFM ratings at 90 PSIG inlet pressure.

L08-Series Miniature Lubricators

Features

- .6 oz. bowl
- Adjustable oil feed
- Full view sight dome
- Fill under pressure design

Specifications

- Maximum operating conditions:
 - transparent bowl: 150 PSIG (10.3 bar) and 14°F to 125°F (-10°C to 52°C)
 - metal bowl: 250 PSIG (17.2 bar) and 14°F to 150°F (-10°C to 65.5°C)

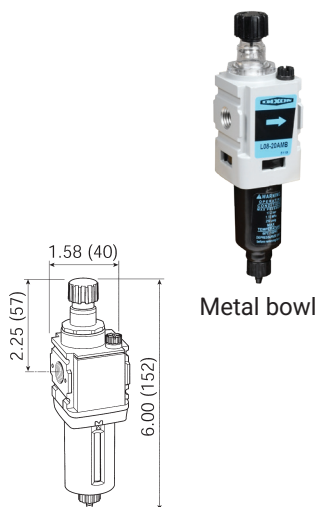

Size	Flow (SCFM)	Transparent Bowl Part #	Metal Bowl Part #
1/4"	52	L08-02A	L08-02AMB

NOTE: See pages 322-326 for accessories.
See page 273 for air tool lubricant.
SCFM ratings at 91.3 PSIG inlet pressure.
FRLs are designed for air service only, unless otherwise indicated.

