

Pharmaceutical Pressure Gauges

Sizes

- Dial size: 3-1/2" or 5" diameter

Features

- Accuracy: $\pm 0.75\%$ of full scale
- Over range capacity: 30%
- Product contact: 316L stainless steel
- Surface finishes (product contact): Ra maximum = 8 microinches
- Standard fill: food grade glycerin
- Rezero feature: standard on pointer
- Shipping weight: approximately 3 lbs. (1.3 kg)

Materials

- Lens: polycarbonate
- Case: 304 stainless steel

Specification

- Temperature limits: 0°F to 250°F (-18°C to 121°C)



3P-D-15U-GFBT

3-1/2" Gauge – (90 mm)

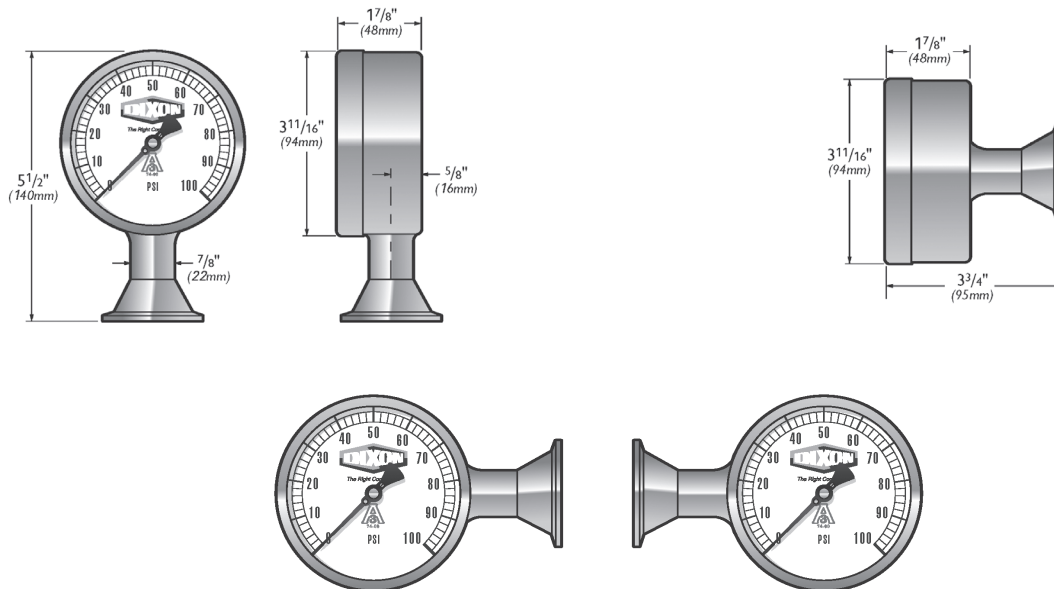

5" Gauge – (120 mm)

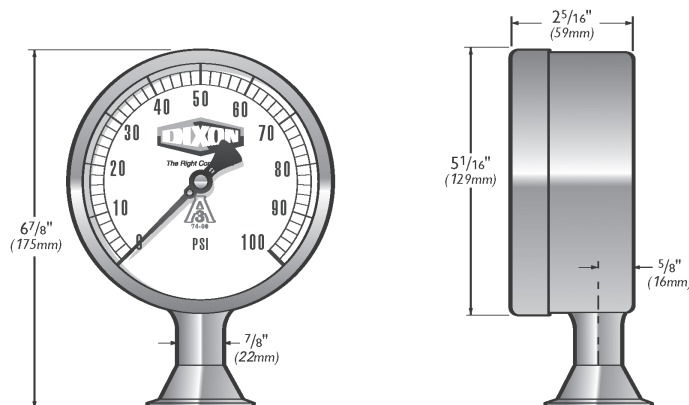

Product not returnable and no cancellations.