

### Carbon Steel Hose Reels

**Sizes**

- 24" stand
- Inlet: brass 1-1/2" MNPT 90° swivel
- Outlet: brass 1-1/2" MNST gooseneck
- 1-1/2" non-collapsible UVX hose (up to 150')

**Features**

- Friction brake
- Left hand inlet
- Right hand inlet
- Red hose reel cover (hose not included)
- Natural, galvanized finish or red powder coated
- Made in USA
- Custom colors available; contact Dixon®

**Materials**

- Reel and frame: heavy-duty welded carbon steel, hot dipped galvanized
- Waterway: brass and stainless steel
- Hardware: 316L stainless steel
- Bearings: greaseless polyethylene
- Hose roller assembly (aluminum or stainless steel brackets)
- Manual rewind hand crank (stainless steel with polyethylene handle)

**Specifications**

- Maximum working water pressure: **200 PSI**
- Inlet: brass 1-1/2" FNPT straight swivel inlet

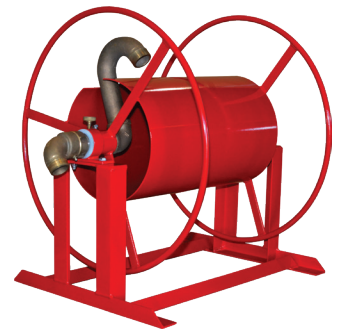
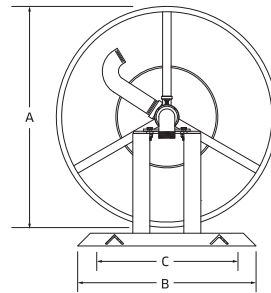
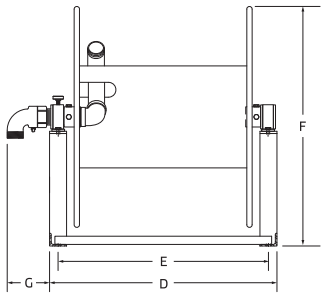

HDR150-100PCR

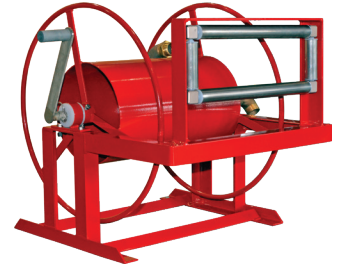
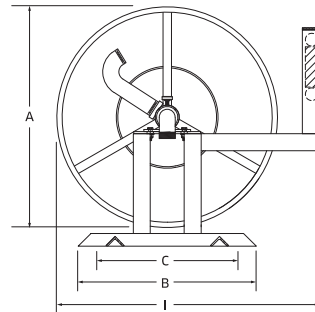
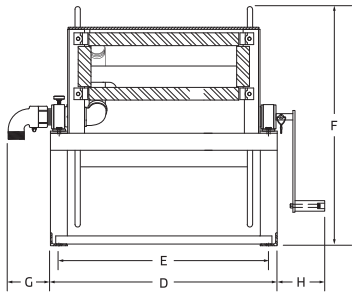

HDR150-100PCRAC

Hose Capacity		Dimensions								
		A	B	C	D	E	F	G	H	I
3/4"	0-250'	26"	21"	17"	26"	24-3/4"	29-3/16"	5"	5-9/16"	31"
1"	0-200'									
1-1/2"	0-150'									

Description	Part #
standard features, galvanized and powder coated (red) finish	HDR150-100PCR
hose roller assembly (aluminum), hand crank, galvanized and powder coated (red) finish	HDR150-100PCRAC
continuous flow reel cover	HDR150-C1